

# SANTINI

quiet point

design / disegno Vladimír Ambroz  
2017



The design of this quiet point is inspired by a church spire created by Santini, a Czech builder of Italian origin who lived in the seventeenth century. His spires complemented the churches they crowned, and there were always several confessionals within for churchgoers.

The Santini quiet point is a modern-day confessional – it allows people to make phone calls undisturbed, and also prevents callers from bothering others with loud conversation. It is suitable for offices, covered public areas and shopping centres.

The bottom part is made from LG HI-MACS, while the top cover is of sheet metal varnished according to customers' requirements. The interior is upholstered with a sound-absorbent material. Please see the catalogue for the range of available colours.

Il design di questo quiet point è ispirato da un campanile progettato da Santini, architetto ceco di origine italiana, che visse nel Seicento. I campanili facevano parte delle chiese e ci si trovavano più confessionali per i praticanti.

Questo è un confessionale moderno – oggetto per telefonare, in modo che il chiamante non sia disturbato e non disturba gli altri con la sua telefonata ad alta voce.

Adatto per uffici, spazi pubblici coperti e centri commerciali. La parte inferiore è prodotta nel materiale LG himacs, il riparo superiore in lamiera verniciata secondo le esigenze del cliente. All'interno c'è tappezzeria prodotta nel materiale fonoassorbente. Colori secondo il catalogo.



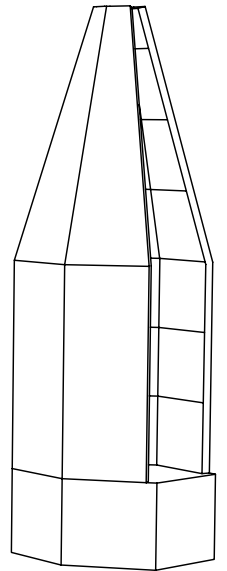
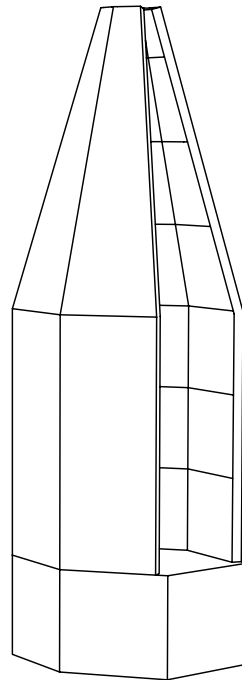
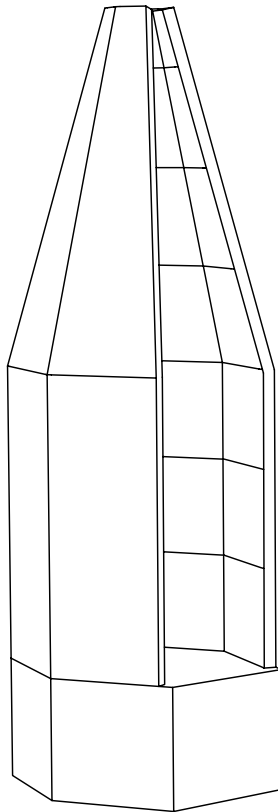
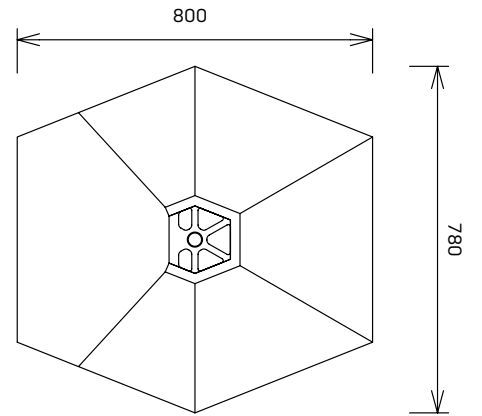
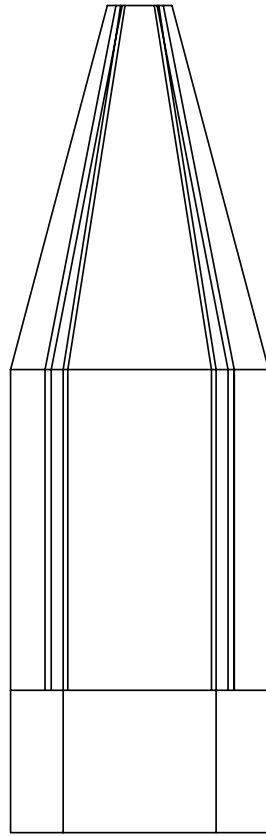
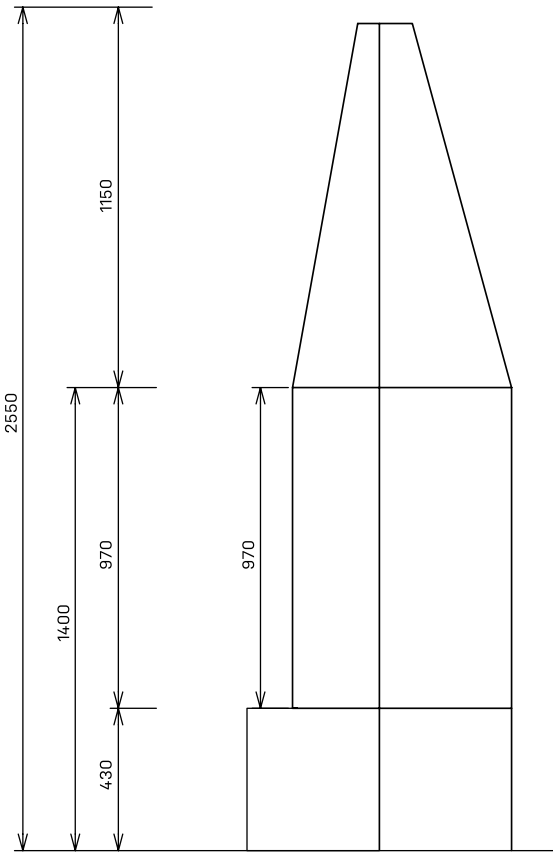



Veřejný prostor je díky dostupnosti sítí a mobilitě telefonujících zahlcen lidmi, kteří telefonují či sledují display svého mobilního telefonu. Když je takovým veřejným prostorem například obchodní centrum s jeho pasážemi a nebo open space office, tak není pro telefonujícího vlastně žádná možnost kam se s telefonem schovat.

A to v případě kdy nechce někoho rušit, být rušen anebo dokonce, nechce, aby byly vidět jeho emoce. Nabízíme zcela nový typ „nábytku“, pro podobné účely. Tzv. tichý bod pod názvem SANTINI evokuje klasičtější věž středoevropských měst či připomíná zpovědnici. Lze dodat nejen v různých odstínech dle projektu ale i variabilně pro vyšší prostory o výšce atakující 3m.

Vnitřní čalounění od firmy Gabriel je akusticky polstrováno a zajišťuje anonymitu i osobní komfort.

Thanks to the ease of access to mobile networks and the mobility of people with phones, today public areas are crowded with phone users making calls or checking their displays.

If such a public area happens to be the arcades of a shopping centre or the interior of an open-plan office, there isn't anywhere for callers to go if they don't want to disturb anyone or be disturbed themselves, or if they wish to hide a private display of emotion.

We are offering a completely new type of "furniture" that solves this problem. Our "quiet point" named SANTINI evokes the classic architecture of a Central European church tower, or is perhaps reminiscent of a confessional. It can be delivered in various colour schemes to suit your project as well as in different height variants ranging up to nearly 3m for extra headroom.

The interior upholstery by Gabriel is acoustically cushioned in order to guarantee anonymity and personal comfort.



production / produzione:  
A.M.O.S. DESIGN /  
contact / contatto:  
amos@amosdesign.cz  
phone / tel:  
+420 777 260 707  
www.amosdesign.cz